

Instruction manual

Compac wheel dolly, model WD1500.

Important: Read and understand the instruction before use!

Operating and service manual for wheel dolly model WD 1500
Max. Capacity 1500 kg.

Instruction and responsibility:

This instruction and safety manual must be enclosed with the wheel dolly at all times.

It is very important that the owner and the operator completely understand the operating, safety and maintenance instructions before use. The manufacturer is not liable for wrong- or irresponsible use or maintenance due to the operators not knowing and following these instructions. If the operator is not fluent in English, then these instructions and warnings shall be read and explained to the operator in the operator's native language, making sure that he understands its contents.

How to use the wheel dolly:

WD1500 is a mobile wheel dolly for demounting and mounting large wheels with an outside diameter of 1150 mm up to 2150 mm (84"). The wheel / load is lifted when the 2 x 4 rollers press horizontally on each side of the wheel. Lifting will require more force in the beginning as the rollers are pressing against each other. Lifting occurs with pumping the handle (P). Lowering the wheel/load is activated by moving the foot pedal (E) into the opposite position. The pump handle (P) can then be used for lowering the wheel/load again.

Operating instruction:

The unit is operated by moving the foot pedal (E) into lifting or lowering position and afterwards pumping the pump handle (P).

Labelling:

Warning and CE approval labels are fitted onto the unit.

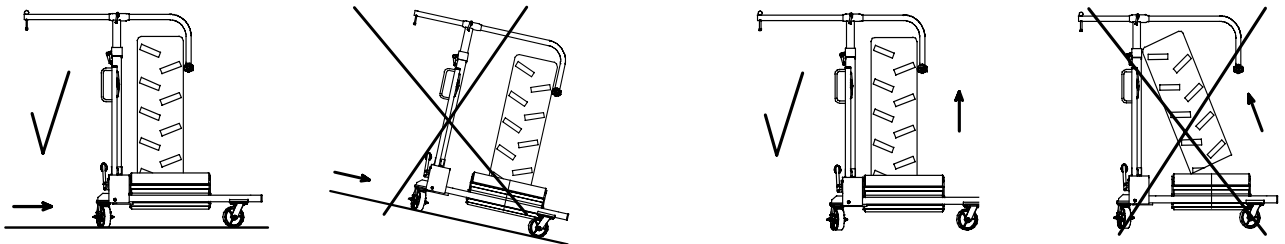

Make sure that lifting **only** occurs on a flat and strong surface / floor.

The wheel/load must be lifted in a vertical angle as the wheel/load might otherwise slide on the rollers away from the unit causing the unit to move towards the operator.

Mounting:

After opening the packaging check the unit for visible damage, leakage, etc. Please recycle or use the packing material again.

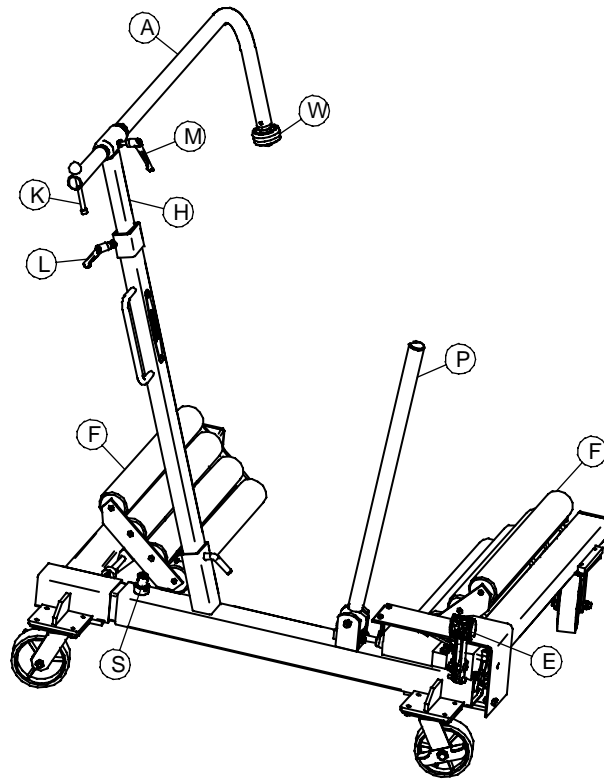

Safety instructions - LIFTING

1. Make sure that lifting only occurs on a flat and strong surface/floor. If not, lifting with this unit is prohibited due to risk of danger / damages!
2. The wheel/load should be lifted from the floor.
3. Place the rollers (F) on either side of the wheel that should be lifted. Move the unit as close to the wheel/load as possible.
4. Loosen the vertical support arm (H) and horizontal support arm (A). By using grip (K) it is possible to steer the arm with the small support wheel (W) to the opposite side of the wheel/load. Once the small support wheel (W) is on the opposite side it can be steered behind the wheel/load. This will prevent the wheel/load from dropping to the opposite side during manoeuvring.
5. Once you have placed the guide arm (A) correctly, lock its position with the lock (M).
6. !! Lock (L) should be open while lifting or lowering so that the wheel (W) supports the wheel/load on the opposite side. Kindly note that you should **NOT** lock position (L). Once you begin lifting the wheel/load, lock (L) **must be open**, as this will allow the guide arm to follow the upwards and downwards movement of the wheel as it is raised and lowered.
7. The lifting can now start. *

* Before you end the lifting procedure, active safety pin (S) so that the manual safety stop is activated, should a hydraulic leak occur. After a short lifting or lowering action the safety pin (S) will be activated. The safety pin is spring loaded and will lock the movement of the lifting arms. To unlock the safety stop pump a little in the opposite direction so that the safety pin (S) can be pulled up again.

Safety instruction - LOWERING / MOUNTING OF WHEEL

1. Release the safety pin (S).
2. Inspect that the small wheel (W) has a firm grip on the wheel/load before lowering.
3. Before lowering the wheel/load make sure that vertical guide lock (L) is released and free to move.
4. Once you slowly start lowering the wheel/load, the guide arm (L) should be able to freely follow the movement of the wheel. If not, the risk is that the wheel will drop away from its support (W) on the opposite side of the wheel and could thereby accidentally fall.
5. Activate the pump lever (P) to lower the load or reach the correct mounting height.
6. Once the unit can be removed from the wheel/load, release locks (K) and swing wheel (W) away from the wheel. Pull back the unit.

Safety instruction - MANOEUVRING WITH WHEEL/LOAD

1. Ensure that the small support wheel (W) is supporting the wheel/load correctly.
2. Ensure that the locks (M), (L) and (S) are in locked position.

WARNING Safety instructions:

Make sure that lifting only occurs on a flat and strong surface/floor.

The wheel/load must be lifted in a vertical angle as the wheel/load might otherwise slide on the rollers away from the unit causing the unit to move towards the operator.

Do not overload the unit! Overloading with loads over 1500 kg could result in damage to the unit or in worst case cause other damage and even accidents!

Lowering a load of more than 1500 kg onto the unit may lead to serious damage to the unit.

Example: If the operator lowers the vehicle itself before lowering and moving the wheel dolly away from the vehicle.

Before lifting / transporting a load the operator MUST take precautions that the load is not allowed to drop, and that the weight distribution is safe. The operator must before use take precautions that all pins are safely locked with split pins or lock rings. (ATTENTION! The LOAD must be blocked with the guide arm (K) locked and (W) in correct position to support the wheels on the opposite side.)

Always lower the load to the lowest possible position before transportation.

Important! The safety valve is calibrated and sealed by the manufacturer and it is ABSOLUTELY PROHIBITED to open the seal or adjust its calibration. Offence against the above safety instructions could in worst case result in loss of the load which could cause personal injury and/or damage to the unit or properties. In case the unit has any irregularities which could affect the safety, the unit must not be operated until it has been repaired.

The unit should not be used if there are any oil leakages or if the unit seems different to use than when it was new. In such cases the unit should be inspected/repared by a skilled person. More information on spare parts, etc is available on www.compac.eu under "Services".

The manufacture is not liable for wrong use, changes to the construction, use of other spare parts than original or adjustments/repairs by unauthorised persons.

Safety Maintenance:

Inspection of the unit must only be done without load, for safety reasons. Only authorized/skilled personnel may repair/adjust the unit. Use only original parts. For adjustment follow the instructions of the manufacturer. For further information please contact www.compac.eu

Maintenance:

At normal use all mechanical/moving parts only requires a monthly lubrication to be maintained. The pins must be greased every three months. **Important!** Use only oil or grease free from acid. An annual inspection must be performed by a skilled person. Every eventually wearing out or defective part must be replaced with original spare parts. The owner and- or user must take precautions that repair is made by a skilled person. Before every use the operator must take precautions that there are no visible faults such as leaks, damage of the WD and loose or missing parts. In case the operator suspects that the unit has been overloaded or wrongly loaded it must before further use be inspected by a skilled person or an authorized.

Oil: DO NOT use brake fluid, motor oil, etc!
Volume: 0.6 litres.
Type: Use only hydraulic oil with a gradation (viscosity) of AWS22.
Compac recommends Castrol.

In case the hydraulic unit has a lack of oil or has been taken apart in order to replace the seals then fill up with the correct oil quantity. Activate the pump handle and add oil slowly through the filling hole at the plug. The lifting arms must be in minimum position (as close together as possible) when refilling oil. Warning! Too much oil quantity might cause problems to the hydraulic system.

Decommissioning:

If the unit should ever be scrapped, draw off the oil into an approved container and dispose it at an approved authority.

10.07.2007 GB/VL